

SKS-GII

SKG/MSG Type

SKS-GII



High metal removal rate

Features 1

Provides stability even milling of deep cavities.

Features 2

4 corner positive insert with low cutting forces.



SKS-GII

SKG/MSG Type

Features 3 Flat top insert

SKG-10 type insert : Max ap=1.5mm

SKG-14 type insert : Max ap=2.5mm



Features 4 Chip breaker insert

Optimized cutting edge for machining of difficult to cut materials like titanium alloy.

Effective for machining that requires reduced cutting loads or long overhang application.



SM breaker for difficult to cut materials



PM breaker for mould steel

Features 5

Insert grades for a wide range of materials

<JC8118><JC8050><JC7550><DS150>



mould steel, hardened steel from 38HRC upto 50HRC
JC8118



mould steel, general steel below 36HRC
JC8050



Titanium alloy, stainless steel
JC7550, DS150

ISO	P					M					K				S				H		
	P01	P10	P20	P30	P40	M01	M10	M20	M30	M40	K01	K10	K20	K30	S01	S10	S20	S30	H01	H10	H20
Range	JC8118										JC8118				NEW DS150				JC8118		
	JC8050																				
						JC7550									JC7550						

Features 6

Excellent chip evacuation

SKS-GII **SKG/MSG Type**

■ **SKG10 Facemill Type**

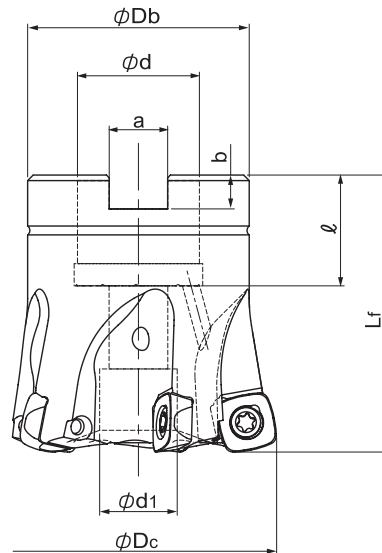

Cat.No.	Stock	No. of inserts	Dimensions (mm)								Arbor set bolt	Weight (kg)	Inserts
			φDc	Lf	φDb	φd	φd1	a	b	ℓ			
SKG-4050R-10-22	●	4	50	50	40	22	14	10.4	6.3	20	M10X1.5X35★	0.3	SPNW10...; SPET10...; SPMT10...
SKG-5050R-10-22	●	5					16.6				M10X1.5X35★	0.3	
SKG-5052R-10-22	●		17				M10	0.3					
SKG-5063R-10-22	●		63		48	27	20	12.4	7	22	M12X1.75X30★	0.5	
SKG-5063R-10-27	●	22				17	10.4	6.3	20	M10	0.5		
SKG-6063R-10-22	●	6	66	50	27	20	12.4	7	22	M12X1.75X30★	0.5		
SKG-6063R-10-27	●									M12X1.75X30★	0.5		
SKG-6066R-10-27	●									M12X1.75X30★	0.6		
SKG-6080R-10-27	●	80	60							M12X1.75X30★	0.9		

Screw	Torque(N.m)	Wrench
TSW-3509H	3.0	A-15T

SKS-GII **SKG/MSG Type**

■ **MSG10 Modular Head Type**

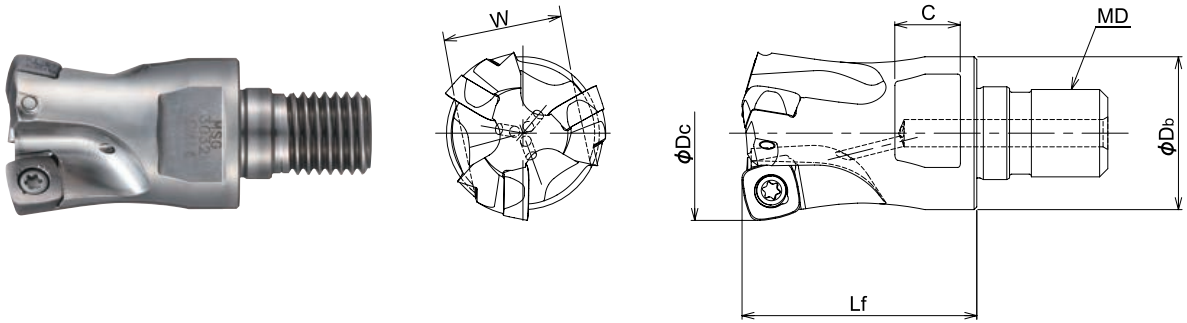
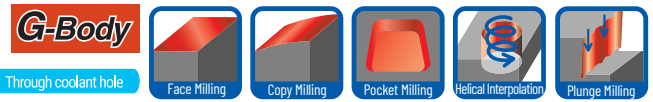

Cat.No.	Stock	No. of inserts	Dimensions (mm)						Inserts
			ϕD_c	Lf	ϕD_b	MD	C	W	
MSG-2025-10-M12	●	2	25	35	23	M12	11	19	SPNW10...; SPET10...; SPMT10...
MSG-3032-10-M16	●	3	32	43	28	M16	12	22	
MSG-3035-10-M16	●		35		14		26		
MSG-4040-10-M16	●	4	40		32				
MSG-4042-10-M16	●		42						

Screw	Torque(N.m)	Wrench
TSW-3509H	3.0	A-15

SKS-GII **SKG/MSG Type**

■ **SKG/MSG10 Type Insert**



Fig. 1

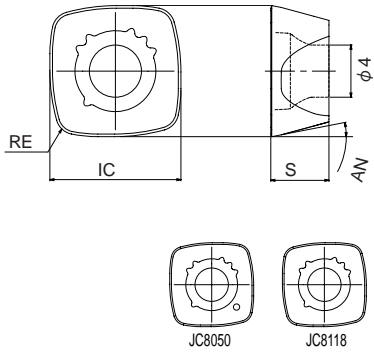

Fig. 2

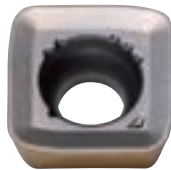
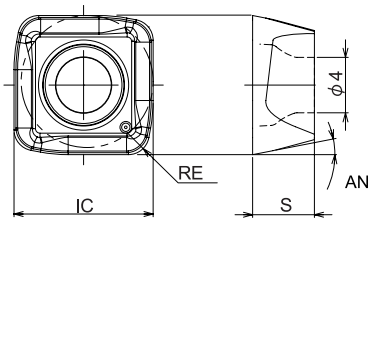

Fig. 3

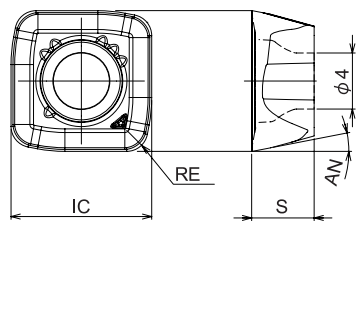
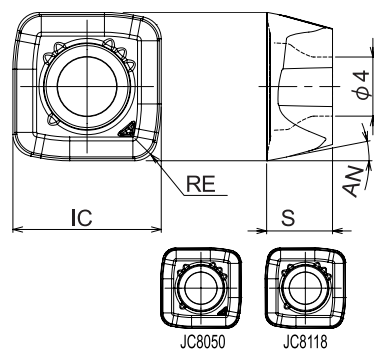

Fig. 4



Cat.No.	Tolerance	PVD Coating				Dimensions (mm)				Fig.
		DS150	JC7550	JC8050	JC8118	RE	IC	S	AN	
SPNW100415ZTR	N			●	●	1.5	10	4.46	11°	1
SPET100415ZPER-SM	E	●	●							2
SPMT100415ZPER-SM	M	●	●							3
SPMT100415ZPTR-PM				●	●					4

SKS-GII **SKG/MSG Type**

■ **MSG10 Modular Head Type**

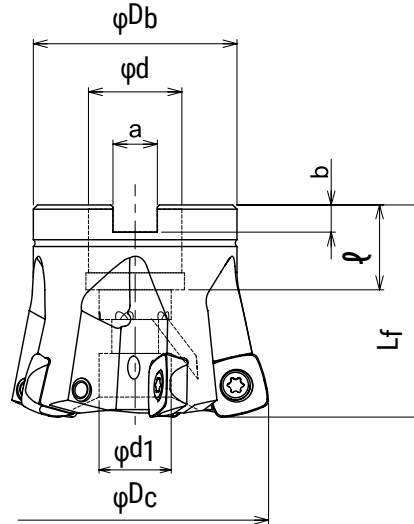
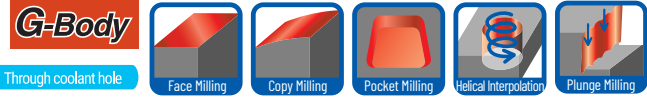

Cat.No.	Stock	No. of inserts	Dimensions (mm)								Arbor set bolt	Weight (kg)	Inserts	Fig.
			φDc	Lf	φDb	φd	φd1	a	b	ρ				
SKG-4050R-14-22	●	4	50	50	40	22	14	10.4	6.3	19.05	M10X1.5X35*	0.3	SPNW14...; SPMT14...	1
SKG-4052R-14-22	●		52		42		17							
SKG-4063R-14-22	●		63		48		20							
SKG-4063R-14-27	●		66		50	27	20	12.4	7	22	M12X1.75X35*	0.5		
SKG-5066R-14-27	●	5	80	60	37	14.4	8	25	M12X1.75X35*	0.5				
SKG-5080R-14-27	●		66	60	37				0.8					
SKG-6100R-14-32	●	6	100	63	70	32	45	14.4	8	25	M16	1.6		

Screw	Torque(N.m)	Wrench
CSW-513H	5.5	A-20

SKS-GII **SKG/MSG Type**

■ **SKG14 Type Insert**



Fig. 1

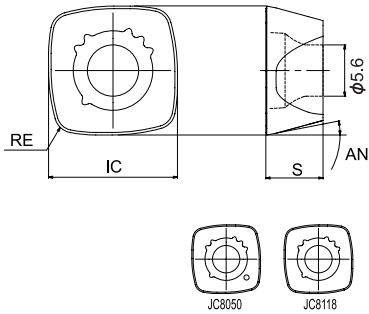

Fig. 2

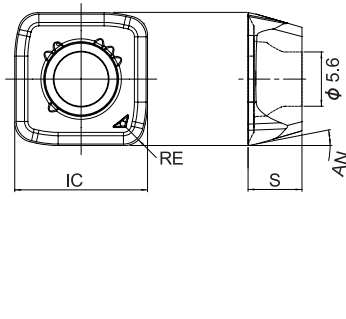
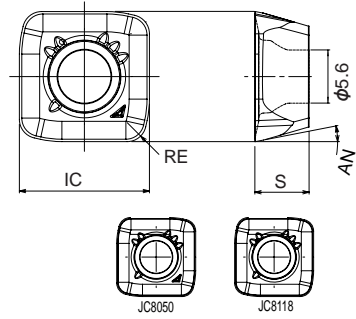

Fig. 3



Cat.No.	Tolerance	PVD Coating				Dimensions (mm)				Fig.
		DS150	JC7550	JC8050	JC8118	RE	IC	S	AN	
SPNW140515ZTR	N			●	●	1.5	13.7	5.56	11°	1
SPMT140520ZPER-SM	M	●	●			2				2
SPMT140520ZPTR-PM				●	●					3

SKS-GII **SKG/MSG Type**

■ Definition of corner shape for programming

● SPNW100415ZTR

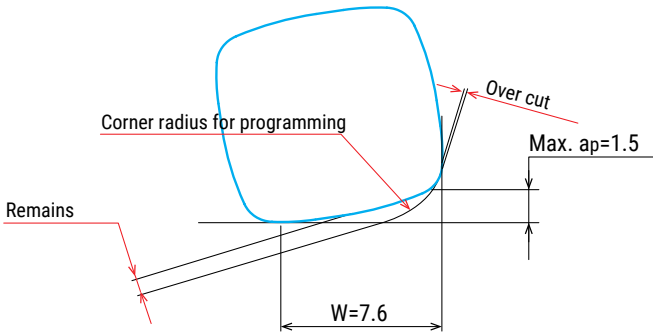

● SPE(M)T100415ZPER-SM
SPMT100415ZPTR-PM

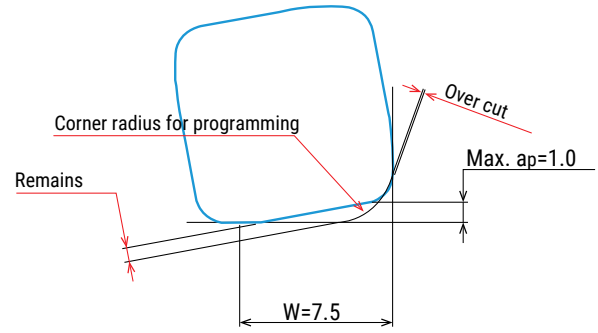

Corner radius for programming	Over cut	Remains
R2.5	0	0.99
R3.0 (Standard)	0	0.84
R3.5	0.09	0.71
R4.0	0.23	0.59

Corner radius for programming	Over cut	Remains
R2.5 (Standard)	0	0.77
R3.0	0.09	0.68
R3.5	0.25	0.60
R4.0	0.43	0.52

● SPNW140515ZTR

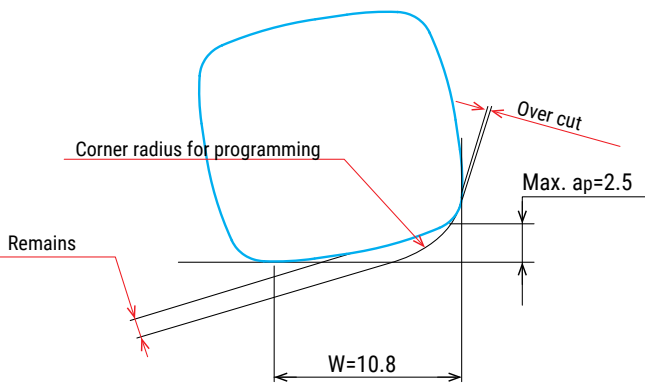

● SPMT140520ZPER-SM
SPMT140520ZPTR-PM

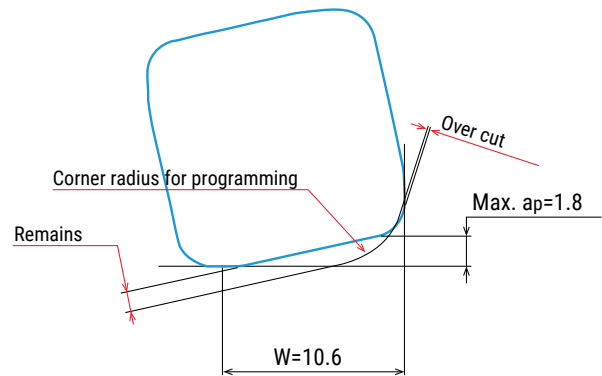

Corner radius for programming	Over cut	Remains
R3.5	0	1.60
R4.0 (Standard)	0	1.46
R4.5	0.06	1.32
R5.0	0.17	1.19

Corner radius for programming	Over cut	Remains
R3.5 (Standard)	0	1.35
R4.0	0.02	1.25
R4.5	0.14	1.12
R5.0	0.29	1.05

SKS-GII

SKG/MSG Type

■ **Recommended Data for Profile Milling**

Ramping

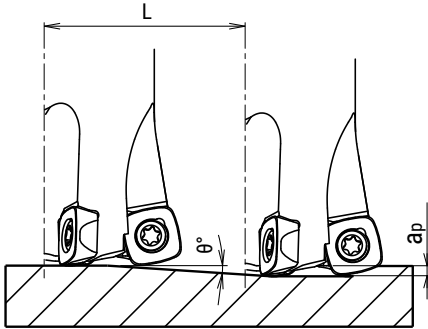

Helical interpolation

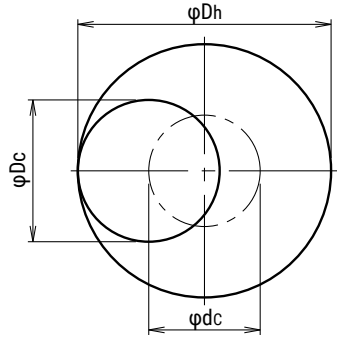

- Calculation of tool pass dia.

$$\varphi_{Dc} = \varphi_{Dh} - \varphi_{Dc}$$

Tool pass dia. Bore dia. Tool Dia.

- Depth of cut per one circuit should not exceed max. depth of cut Ap
- Down cutting is recommended, tool pass rotation should be counterclockwise

- In case of ramping and helical interpolation, apply 70% or less feed (Vf) from standard cutting condition table.

● **SPNW100415ZTR / SPNW140515ZTR**

Cat.No.	Tool dia. (mm)	Effective Cutting dia. (mm)	Max. depth of cut: ap (mm)	Ramping		Helical interpolation	
				Max. ramping angle θ	Total cutting length at Max. (ap) : L (mm)	Min. Bore dia. Dh min. (mm)	Max. Bore dia. Dh max. (mm)
MSG-2025-10	25	9.8	1.5	1°	85.9	36	48
MSG-3032-10	32	16.8	1.5	1°	85.9	50	62
MSG-3035-10	35	19.8	1.5	1°	85.9	56	70
MSG-4040-10	40	24.8	1.5	1°	85.9	66	78
MSG-4042-10	42	26.8	1.5	1°	85.9	70	82
SKG-*050R-10	50	34.8	1.5	1°	85.9	86	98
SKG-5052R-10	52	36.8	1.5	1°	85.9	90	102
SKG-*063R-10	63	47.8	1.5	0°45'	114.6	112	124
SKG-6066R-10	66	50.8	1.5	0°45'	114.6	118	130
SKG-6080R-10	80	64.8	1.5	0°30'	171.9	146	158
SKG-4050R-14	50	28.4	2.5	1°	143.2	80	98
SKG-4052R-14	52	30.4	2.5	1°	143.2	84	102
SKG-*063R-14	63	41.4	2.5	0°45'	191	106	124
SKG-5066R-14	66	44.4	2.5	0°45'	191	112	130
SKG-5080R-14	80	58.4	2.5	0°30'	286.5	140	158
SKG-6100R-14	100	78.4	2.5	0°20'	430	180	198
SKG-6125R-14	125	103.4	2.5	0°20'	430	230	248
SKG-7160R-14	160	138.4	2.5	0°15'	573	300	318

SKS-GII **SKG/MSG Type**

Recommended Data for Profile Milling

Ramping

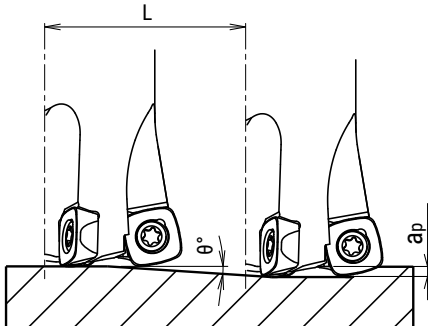

Helical interpolation

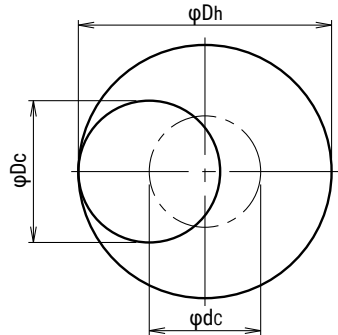

● Calculation of tool pass dia.

$$\phi Dc = \phi Dh - \phi Dc$$

Tool pass dia. Bore dia. Tool Dia.

● Depth of cut per one circuit should not exceed max. depth of cut Ap

● Down cutting is recommended, tool pass rotation should be counterclockwise

● In case of ramping and helical interpolation, apply 70% or less feed (Vf) from standard cutting condition table.

- SPE (M) T100415ZPER-SM, SPMT100415ZPTR-PM
- SPMT140520ZPER-SM, SPMT140520ZPTR-PM

Cat.No.	Tool dia. (mm)	Effective Cutting dia. (mm)	Max. depth of cut : ap (mm)	Ramping		Helical interpolation	
				Max. ramping angle θ	Total cutting length at Max. (ap) : L (mm)	Min. Bore dia. Dh min. (mm)	Max. Bore dia. Dh max. (mm)
MSG-2025-10	25	10	1.0	1°	57.3	36	48
MSG-3032-10	32	17	1.0	1°	57.3	50	62
MSG-3035-10	35	20	1.0	1°	57.3	56	70
MSG-4040-10	40	25	1.0	1°	57.3	66	78
MSG-4042-10	42	27	1.0	1°	57.3	70	82
SKG-*050R-10	50	35	1.0	1°	57.3	86	98
SKG-5052R-10	52	37	1.0	1°	57.3	90	102
SKG-*063R-10	63	48	1.0	0°45'	76.4	112	124
SKG-6066R-10	66	51	1.0	0°45'	76.4	118	130
SKG-6080R-10	80	65	1.0	0°30'	114.6	146	158
SKG-4050R-14	50	28.8	1.8	1°	103.1	80	98
SKG-4052R-14	52	30.8	1.8	1°	103.1	84	102
SKG-*063R-14	63	41.8	1.8	0°45'	137.5	106	124
SKG-5066R-14	66	44.8	1.8	0°45'	137.5	112	130
SKG-5080R-14	80	58.8	1.8	0°30'	206.3	140	158
SKG-6100R-14	100	78.8	1.8	0°20'	206.3	180	198
SKG-6125R-14	125	123.8	1.8	0°20'	206.3	230	248
SKG-7160R-14	160	138.8	1.8	0°15'	412.5	300	318

SKS-GII**SKG/MSG Type**

■ Recommended cutting conditions

● MSG Type + MSN shank

Material	Grade	Tool dia.(mm)														
		25					32/35					40/42				
		2N					3N					4N				
		ℓ (mm)	ap (mm)	ae (mm)	n (min ⁻¹)	Vf (mm/min)	ℓ (mm)	ap (mm)	ae (mm)	n (min ⁻¹)	Vf (mm/min)	ℓ (mm)	ap (mm)	ae (mm)	n (min ⁻¹)	Vf (mm/min)
Carbon steel (S50C, S55C) below 250HB	JC8050	~75	1	~9	2,290	6,870	~100	1	~14	1,640	7,380	~100	1	~24	1,430	8,580
	(JC8118)	125	0.8	~9	2,290	6,870	150	0.8	~14	1,640	7,380	150	0.8	~24	1,430	8,580
	SPNW SPMTPM	175	0.6	~9	2,290	6,410	210	0.6	~14	1,640	6,890	210	0.6	~24	1,430	8,010
Tool & die steel (SKD61, SKD11) below 255HB	JC8050	~75	1	~9	1,910	5,730	~100	1	~14	1,360	6,120	~100	1	~24	1,190	7,140
	(JC8118)	125	0.8	~9	1,910	5,730	150	0.8	~14	1,360	6,120	150	0.8	~24	1,190	7,140
	SPNW SPMTPM	175	0.6	~9	1,910	5,350	210	0.6	~14	1,360	5,710	210	0.6	~24	1,190	6,660
Mold steel (HPM7, PX5, P20) 30-36 HRC	JC8050	~75	1	~9	1,910	5,730	~100	1	~14	1,360	6,120	~100	1	~24	1,190	7,140
	(JC8118)	125	0.8	~9	1,910	5,730	150	0.8	~14	1,360	6,120	150	0.8	~24	1,190	7,140
	SPNW SPMTPM	175	0.6	~9	1,910	5,350	210	0.6	~14	1,360	5,710	210	0.6	~24	1,190	6,660
Mold steel (NAK80, HPM1, P21) 38-43HRC	JC8118	~75	1	~9	1,400	3,640	~100	1	~14	1,000	3,900	~100	1	~24	880	4,580
	(JC8050)	125	0.8	~9	1,400	3,640	150	0.8	~14	1,000	3,900	150	0.8	~24	880	4,580
	SPNW SPMTPM	175	0.6	~9	1,400	3,360	210	0.6	~14	1,000	3,600	210	0.6	~24	880	4,220
Hardened die steel (SKD61, DAC, DHA) 42-52HRC	JC8118	~75	0.6	~9	1,270	3,050	~100	0.6	~14	910	3,280	~100	0.6	~24	800	3,840
	SPNW	125	0.4	~9	1,270	3,050	150	0.4	~14	910	3,280	150	0.4	~24	800	3,840
		175	0.3	~9	1,270	2,540	210	0.3	~14	910	2,730	210	0.3	~24	800	3,200
Gery & Nodular cast iron (FC, FCD) below 300HB	JC8118	~75	1.2★	~9	2,290	6,870	~100	1.2★	~14	1,640	7,380	~100	1.2★	~24	1,430	8,580
	SPNW	125	1	~9	2,290	6,870	150	1	~14	1,640	7,380	150	1	~24	1,430	8,580
	SPMTPM	175	0.8	~9	2,290	6,870	210	0.8	~14	1,640	7,380	210	0.8	~24	1,430	8,580
Stainless steel (SUS304) below 250HB	JC7550	~75	1	~9	1,910	3,820	~100	1	~14	1,360	4,080	~100	1	~24	1,190	4,760
	SPMT-SM	125	0.8	~9	1,910	3,820	150	0.8	~14	1,360	4,080	150	0.8	~24	1,190	4,760
	SPET-SM	175	0.6	~9	1,660	2,990	210	0.6	~14	1,180	3,190	210	0.6	~24	1,030	3,710
Titanium alloy (Ti-6Al-4V)	DS150	~75	1	~9	760	910	~100	1	~14	550	990	~100	1	~24	480	1,150
	SPMT-SM	125	0.8	~9	760	910	150	0.8	~14	550	990	150	0.8	~24	480	1,150
	SPET-SM	175	0.6	~9	760	760	210	0.6	~14	550	830	210	0.6	~24	480	960

Note

1. Please adjust cutting conditions according to machine rigidity or work rigidity. (the above table is guide for cutting on a #50 BT machine.)
2. In case of chatter occurring, recommended to reduce ap or rpm and keep feed per tooth.
3. ap should be reduced when using on low rigidity machine.
4. Use air blow.

★: ap ≤ 1.0 when using SPMT10/SPET10 insert.

SKS-GII**SKG/MSG Type**

■ Recommended cutting conditions

● SKG10 Type

Material	Grade	Tool dia.(mm)														
		50					50/52					63				
		4N					5N					5N				
		ℓ (mm)	a _p (mm)	a _e (mm)	n (min ⁻¹)	V _f (mm/min)	ℓ (mm)	a _p (mm)	a _e (mm)	n (min ⁻¹)	V _f (mm/min)	ℓ (mm)	a _p (mm)	a _e (mm)	n (min ⁻¹)	V _f (mm/min)
Carbon steel (S50C, S55C) below 250HB	JC8050 (JC8118) SPNW SPMT-PM	~150	1.5★	~32	1,020	7,340	~150	1.5★	~32	1,020	9,180	~150	1.5★	~44	810	7,290
		200	1.2★	~32	1,020	7,340	200	1.2★	~32	1,020	9,180	200	1.5★	~44	810	7,290
		250	0.8	~32	890	5,340	250	0.8	~32	890	6,680	250	1.2★	~44	710	5,330
		300	0.6	~32	830	4,980	300	0.6	~32	830	6,230	300	1	~44	660	4,950
		350	0.5	~32	830	4,650	350	0.5	~32	830	5,810	350	0.5	~44	660	4,620
Tool & die steel (SKD61, SKD11) below 255HB	JC8050 (JC8118) SPNW SPMT-PM	~150	1.5★	~32	1,020	7,340	~150	1.5★	~32	1,020	9,180	~150	1.5★	~44	810	7,290
		200	1.2★	~32	1,020	7,340	200	1.2★	~32	1,020	9,180	200	1.5★	~44	810	7,290
		250	0.8	~32	890	5,340	250	0.8	~32	890	6,680	250	1.2★	~44	710	5,330
		300	0.6	~32	830	4,980	300	0.6	~32	830	6,230	300	1	~44	660	4,950
		350	0.5	~32	830	4,650	350	0.5	~32	830	5,810	350	0.5	~44	660	4,620
Mold steel (HPM7, PX5, P20) 30-36 HRC	JC8050 (JC8118) SPNW SPMT-PM	~150	1.5★	~32	1,020	7,340	~150	1.5★	~32	1,020	9,180	~150	1.5★	~44	810	7,290
		200	1.2★	~32	1,020	7,340	200	1.2★	~32	1,020	9,180	200	1.5★	~44	810	7,290
		250	0.8	~32	890	5,340	250	0.8	~32	890	6,680	250	1.2★	~44	710	5,330
		300	0.6	~32	830	4,980	300	0.6	~32	830	6,230	300	1	~44	660	4,950
		350	0.5	~32	830	4,650	350	0.5	~32	830	5,810	350	0.5	~44	660	4,620
Mold steel (NAK80, HPM1, P21) 38-43HRC	JC8118 (JC8050) SPNW SPMT-PM	~150	1.2★	~32	700	4,200	~150	1.2★	~32	700	5,250	~150	1.2★	~44	560	4,200
		200	1	~32	700	4,200	200	1	~32	700	5,250	200	1.2★	~44	560	4,200
		250	0.7	~32	640	3,840	250	0.7	~32	640	4,800	250	1	~44	510	3,830
		300	0.6	~32	510	2,860	300	0.6	~32	510	3,570	300	0.5	~44	400	2,800
		350	-	-	-	-	350	-	-	-	-	350	-	-	-	-
Hardened die steel (SKD61, DAC, DHA) 42-52HRC	JC8118 SPNW	~150	1	~32	640	3,580	~150	1	~32	640	4,480	~150	1	~44	510	3,570
		200	0.8	~32	640	3,330	200	0.8	~32	640	4,160	200	0.8	~44	510	3,320
		250	0.6	~32	640	3,070	250	0.6	~32	640	3,840	250	0.6	~44	510	3,060
		300	-	-	-	-	300	-	-	-	-	300	-	-	-	-
		350	-	-	-	-	350	-	-	-	-	350	-	-	-	-
Grey & Nodular cast iron (FC, FCD) below 300HB	JC8118 SPNW SPMT-PM	~150	1.5★	~32	1,150	8,280	~150	1.5★	~32	1,150	10,350	~150	1.5★	~44	910	8,190
		200	1.5★	~32	1,150	8,280	200	1.5★	~32	1,150	10,350	200	1.5★	~44	910	8,190
		250	1.2★	~32	1,150	6,900	250	1.2★	~32	1,150	8,630	250	1.2★	~44	910	6,830
		300	0.8	~32	1,020	6,120	300	0.8	~32	1,020	7,650	300	0.8	~44	810	6,080
		350	0.5	~32	1,020	6,120	350	0.5	~32	1,020	7,650	350	0.5	~44	810	6,080
Stainless steel (SUS304) below 250HB	JC7550 SPMT-SM SPET-SM	~150	1	~32	950	4,940	~150	1	~32	950	6,180	~150	1	~44	760	5,320
		200	1	~32	950	4,940	200	1	~32	950	6,180	200	1	~44	760	4,940
		250	0.8	~32	830	3,980	250	0.8	~32	830	4,980	250	0.8	~44	660	3,960
		300	0.6	~32	760	3,040	300	0.6	~32	760	3,800	300	0.6	~44	610	3,050
		350	0.4	~32	640	2,560	350	0.4	~32	640	3,200	350	0.5	~44	510	2,550
Titanium alloy (Ti-6Al-4V)	DS150 SPMT-SM SPET-SM	~150	1	~32	380	910	~150	1	~32	380	1,140	~150	1	~44	300	900
		200	0.8	~32	380	910	200	0.8	~32	380	1,140	200	0.8	~44	300	900
		250	0.6	~32	380	760	250	0.6	~32	380	950	250	0.6	~44	300	750
		300	0.4	~32	380	610	300	0.4	~32	380	760	300	0.4	~44	300	600
		350	-	-	-	-	350	-	-	-	-	350	-	-	-	-

Note

1. Please adjust cutting conditions according to machine rigidity or work rigidity. (the above table is guide for cutting on a #50 BT machine.)
2. In case of chatter occurring, recommended to reduce a_p or rpm and keep feed per tooth.
3. a_p should be reduced when using on low rigidity machine.
4. Use air blow.

★: a_p ≤ 1.0 when using SPMT10/SPET10 insert.

SKS-GII

SKG/MSG Type

■ Recommended cutting conditions

● SKG10 Type

Material	Grade	Tool dia.(mm)									
		63/66					80				
		6N					6N				
		ℓ (mm)	ap (mm)	ae (mm)	n (min ⁻¹)	Vf (mm/min)	ℓ (mm)	ap (mm)	ae (mm)	n (min ⁻¹)	Vf (mm/min)
Carbon steel (S50C, S55C) below 250HB	JC8050 (JC8118) SPNW SPMT-PM	~150	1.5★	~44	810	8,750	~150	1.5★	~60	640	6,910
		200	1.5★	~44	810	8,750	200	1.5★	~60	640	6,910
		250	1.2★	~42	710	6,390	250	1.2★	~55	560	5,040
		300	1	~42	660	5,940	300	1	~55	520	4,680
		350	0.5	~42	660	5,540	350	0.5	~55	520	4,370
Tool & die steel (SKD61, SKD11) below 255HB	JC8050 (JC8118) SPNW SPMT-PM	~150	1.5★	~44	810	8,750	~150	1.5★	~60	640	6,910
		200	1.5★	~44	810	8,750	200	1.5★	~60	640	6,910
		250	1.2★	~42	710	6,390	250	1.2★	~55	560	5,040
		300	1	~42	660	5,940	300	1	~55	520	4,680
		350	0.5	~42	660	5,540	350	0.5	~55	520	4,370
Mold steel (HPM7, PX5, P20) 30-36 HRC	JC8050 (JC8118) SPNW SPMT-PM	~150	1.5★	~44	810	8,750	~150	1.5★	~60	640	6,910
		200	1.5★	~44	810	8,750	200	1.5★	~60	640	6,910
		250	1.2★	~42	710	6,390	250	1.2★	~55	560	5,040
		300	1	~42	660	5,940	300	1	~55	520	4,680
		350	0.5	~42	660	5,540	350	0.5	~55	520	4,370
Mold steel (NAK80, HPM1, P21) 38-43HRC	JC8118 (JC8050) SPNW SPMT-PM	~150	1.2★	~44	560	5,040	~150	1.2★	~60	440	3,960
		200	1.2★	~44	560	5,040	200	1.2★	~60	440	3,960
		250	1	~42	510	4,590	250	1	~55	400	3,600
		300	0.5	~42	400	3,360	300	0.5	~55	320	2,690
		350	-	-	-	-	350	-	-	-	-
Hardened die steel (SKD61, DAC, DHA) 42-52HRC	JC8118 SPNW	~150	1	~44	510	4,280	~150	1	~60	400	3,360
		200	0.8	~44	510	3,980	200	0.8	~60	400	3,120
		250	0.6	~42	510	3,670	250	0.6	~55	400	2,880
		300	-	-	-	-	300	-	-	-	-
		350	-	-	-	-	350	-	-	-	-
Grey & Nodular cast iron (FC, FCD) below 300HB	JC8118 SPNW SPMT-PM	~150	1.5★	~44	910	9,830	~150	1.5★	~60	720	7,780
		200	1.5★	~44	910	9,830	200	1.5★	~60	720	7,780
		250	1.2★	~42	910	8,190	250	1.2★	~55	720	6,480
		300	0.8	~42	810	7,290	300	0.8	~55	640	5,760
		350	0.5	~42	810	7,290	350	0.5	~55	640	5,760
Stainless steel (SUS304) below 250HB	JC7550 SPMT-SM SPET-SM	~150	1	~44	760	6,380	~150	1	~60	600	5,040
		200	1	~44	760	5,930	200	1	~60	600	4,680
		250	0.8	~42	660	4,750	250	0.8	~55	520	3,740
		300	0.6	~42	610	3,660	300	0.6	~55	480	2,880
		350	0.5	~42	510	3,060	350	0.5	~55	400	2,400
Titanium alloy (Ti-6Al-4V)	DS150 SPMT-SM SPET-SM	~150	1	~44	300	1,080	~150	1	~60	240	860
		200	0.8	~44	300	1,080	200	0.8	~60	240	860
		250	0.6	~42	300	900	250	0.6	~55	240	720
		300	0.4	~42	300	720	300	0.4	~55	240	580
		350	-	-	-	-	350	-	-	-	-

Note

1. Please adjust cutting conditions according to machine rigidity or work rigidity. (the above table is guide for cutting on a #50 BT machine.)
2. In case of chatter occurring, recommended to reduce ap or rpm and keep feed per tooth.
3. ap should be reduced when using on low rigidity machine.
4. Use air blow.

★: ap ≤ 1.0 when using SPMT10/SPET10 insert.

SKS-GII**SKG/MSG Type**

■ Recommended cutting conditions

● SKG14 Type

		50/52					63					66				
		4N					4N					5N				
		ℓ	ap	ae	n	Vf	ℓ	ap	ae	n	Vf	ℓ	ap	ae	n	Vf
		(mm)	(mm)	(mm)	(min ⁻¹)	(mm/min)	(mm)	(mm)	(mm)	(min ⁻¹)	(mm/min)	(mm)	(mm)	(mm)	(min ⁻¹)	(mm/min)
Carbon steel (S50C, S55C) below 250HB	JC8050 (JC8118) SPNW SPMT-PM	~150	2★	~28	890	6,410	~150	2★	~40	710	5,110	~150	2★	~44	680	6,120
		200	1.8	~28	890	6,410	200	1.8	~40	710	5,110	200	1.8	~44	680	6,120
		250	1.5	~28	830	4,980	250	1.5	~40	660	3,960	250	1.5	~44	630	4,730
		300	0.8	~28	760	4,560	300	0.8	~40	610	3,660	300	0.8	~44	580	4,350
		350	0.6	~28	640	3,580	350	0.6	~40	510	2,860	350	0.6	~44	480	3,360
Tool & die steel (SKD61, SKD11) below 255HB	JC8050 (JC8118) SPNW SPMT-PM	~150	2★	~28	890	6,410	~150	2★	~40	710	5,110	~150	2★	~44	680	6,120
		200	1.8	~28	890	6,410	200	1.8	~40	710	5,110	200	1.8	~44	680	6,120
		250	1.5	~28	830	4,980	250	1.5	~40	660	3,960	250	1.5	~44	630	4,730
		300	0.8	~28	760	4,560	300	0.8	~40	610	3,660	300	0.8	~44	580	4,350
		350	0.6	~28	640	3,580	350	0.6	~40	510	2,860	350	0.6	~44	480	3,360
Mold steel (HPM7, PX5, P20) 30-36 HRC	JC8050 (JC8118) SPNW SPMT-PM	~150	2★	~28	890	6,410	~150	2★	~40	710	5,110	~150	2★	~44	680	6,120
		200	1.8	~28	890	6,410	200	1.8	~40	710	5,110	200	1.8	~44	680	6,120
		250	1.5	~28	830	4,980	250	1.5	~40	660	3,960	250	1.5	~44	630	4,730
		300	0.8	~28	760	4,560	300	0.8	~40	610	3,660	300	0.8	~44	580	4,350
		350	0.6	~28	640	3,580	350	0.6	~40	510	2,860	350	0.6	~44	480	3,360
Mold steel (NAK80, HPM1, P21) 38-43HRC	JC8118 (JC8050) SPNW SPMT-PM	~150	1.6	~28	640	3,840	~150	1.6	~40	510	3,060	~150	1.6	~44	480	3,600
		200	1.4	~28	640	3,840	200	1.4	~40	510	3,060	200	1.4	~44	480	3,600
		250	1.2	~28	640	3,840	250	1.2	~40	510	3,060	250	1.2	~44	480	3,600
		300	0.7	~28	510	2,860	300	0.7	~40	400	2,240	300	0.7	~44	390	2,730
		350	-	-	-	-	350	-	-	-	-	350	-	-	-	-
Hardened die steel (SKD61, DAC, DHA) 42-52HRC	JC8118 SPNW	~150	1	~28	570	2,740	~150	1	~40	450	2,160	~150	1	~44	430	2,580
		200	1	~28	570	2,280	200	1	~40	450	1,800	200	1	~44	430	2,150
		250	0.8	~28	570	1,820	250	0.8	~40	450	1,440	250	0.8	~44	430	1,720
		300	0.5	~28	450	1,260	300	0.5	~40	350	980	300	0.5	~44	340	1,190
		350	-	-	-	-	350	-	-	-	-	350	-	-	-	-
Grey & Nodular cast iron (FC, FCD) below 300HB	JC8118 SPNW SPMT-PM	~150	2★	~28	1,150	8,280	~150	2★	~40	910	6,550	~150	2★	~44	870	7,830
		200	1.8	~28	1,150	8,280	200	1.8	~40	910	6,550	200	1.8	~44	870	7,830
		250	1.5	~28	1,150	6,900	250	1.5	~40	910	5,460	250	1.5	~44	870	6,530
		300	0.8	~28	1,020	6,120	300	0.8	~40	810	4,860	300	0.8	~44	770	5,780
		350	0.6	~28	1,020	5,710	350	0.6	~40	810	4,540	350	0.6	~44	770	5,390
Stainless steel (SUS304) below 250HB	JC7550 SPMT-SM	~150	1.3	~28	950	4,940	~150	1.3	~40	760	4,260	~150	1.3	~44	760	5,320
		200	1.3	~28	950	4,940	200	1.3	~40	760	3,950	200	1.3	~44	760	4,940
		250	1.1	~28	830	3,980	250	1.1	~40	660	3,170	250	1.1	~44	660	3,960
		300	0.9	~28	760	3,040	300	0.9	~40	610	2,440	300	0.9	~44	610	3,050
		350	0.7	~28	640	2,560	350	0.7	~40	510	2,040	350	0.7	~44	510	2,550
Titanium alloy (Ti-6Al-4V)	DS150 SPMT-SM	~150	1.3	~28	380	910	~150	1.3	~40	300	720	~150	1.3	~44	300	900
		200	1.1	~28	380	910	200	1.1	~40	300	720	200	1.1	~44	300	900
		250	0.9	~28	380	760	250	0.9	~40	300	600	250	0.9	~44	300	750
		300	0.7	~28	380	610	300	0.7	~40	300	480	300	0.7	~44	300	600
		350	-	-	-	-	350	-	-	-	-	350	-	-	-	-

Note

1. Please adjust cutting conditions according to machine rigidity or work rigidity. (the above table is guide for cutting on a #50 BT machine.)
2. In case of chatter occurring, recommended to reduce ap or rpm and keep feed per tooth.
3. ap should be reduced when using on low rigidity machine.
4. Use air blow.

★: ap ≤ 1.8 when using SPMT14 insert.

SKS-GII

SKG/MSG Type

■ Recommended cutting conditions

● SKG14 Type

Material	Grade	Tool dia.(mm)														
		80					100					125				
		5N					6N					6N				
		ℓ (mm)	a _p (mm)	a _e (mm)	n (min ⁻¹)	V _f (mm/min)	ℓ (mm)	a _p (mm)	a _e (mm)	n (min ⁻¹)	V _f (mm/min)	ℓ (mm)	a _p (mm)	a _e (mm)	n (min ⁻¹)	V _f (mm/min)
Carbon steel (S50C, S55C) below 250HB	JC8050 (JC8118) SPNW SPMT-PM	~150	2★	~56	600	5,400	~150	2★	~70	480	5,180	~150	2★	~87	380	4,100
		200	1.8	~56	600	5,400	200	1.8	~70	480	5,180	200	1.8	~87	380	4,100
		250	1.5	~56	560	4,200	250	1.5	~70	450	4,050	250	1.5	~87	360	3,240
		300	0.8	~56	520	3,900	300	0.8	~70	410	3,690	300	0.8	~87	330	2,970
		350	0.6	~56	440	3,080	350	0.6	~70	350	2,940	350	0.6	~87	280	2,350
Tool & die steel (SKD61, SKD11) below 255HB	JC8050 (JC8118) SPNW SPMT-PM	~150	2★	~56	600	5,400	~150	2★	~70	480	5,180	~150	2★	~87	380	4,100
		200	1.8	~56	600	5,400	200	1.8	~70	480	5,180	200	1.8	~87	380	4,100
		250	1.5	~56	560	4,200	250	1.5	~70	450	4,050	250	1.5	~87	360	3,240
		300	0.8	~56	520	3,900	300	0.8	~70	410	3,690	300	0.8	~87	330	2,970
		350	0.6	~56	440	3,080	350	0.6	~70	350	2,940	350	0.6	~87	280	2,350
Mold steel (HPM7, PX5, P20) 30-36 HRC	JC8050 (JC8118) SPNW SPMT-PM	~150	2★	~56	600	5,400	~150	2★	~70	480	5,180	~150	2★	~87	380	4,100
		200	1.8	~56	600	5,400	200	1.8	~70	480	5,180	200	1.8	~87	380	4,100
		250	1.5	~56	560	4,200	250	1.5	~70	450	4,050	250	1.5	~87	360	3,240
		300	0.8	~56	520	3,900	300	0.8	~70	410	3,690	300	0.8	~87	330	2,970
		350	0.6	~56	440	3,080	350	0.6	~70	350	2,940	350	0.6	~87	280	2,350
Mold steel (NAK80, HPM1, P21) 38-43HRC	JC8118 (JC8050) SPNW SPMT-PM	~150	1.6	~56	400	3,000	~150	1.6	~70	320	2,880	~150	1.6	~87	250	2,250
		200	1.4	~56	400	3,000	200	1.4	~70	320	2,880	200	1.4	~87	250	2,250
		250	1.2	~56	400	3,000	250	1.2	~70	320	2,880	250	1.2	~87	250	2,250
		300	0.7	~56	320	2,240	300	0.7	~70	250	2,100	300	0.7	~87	200	1,680
		350	-	-	-	-	350	-	-	-	-	350	-	-	-	-
Hardened die steel (SKD61, DAC, DHA) 42-52HRC	JC8118 SPNW	~150	1	~56	360	2,160	~150	1	~70	290	2,090	~150	1	~87	230	1,660
		200	1	~56	360	1,800	200	1	~70	290	1,740	200	1	~87	230	1,380
		250	0.8	~52	360	1,440	250	0.8	~60	290	1,390	250	0.8	~75	230	1,100
		300	0.5	~52	280	980	300	0.5	~60	220	920	300	0.5	~75	180	760
		350	-	-	-	-	350	-	-	-	-	350	-	-	-	-
Grey & Nodular cast iron (FC, FCD) below 300HB	JC8118 SPNW SPMT-PM	~150	2★	~56	720	6,480	~150	2★	~70	570	6,160	~150	2★	~87	460	4,970
		200	1.8	~56	720	6,480	200	1.8	~70	570	6,160	200	1.8	~87	460	4,970
		250	1.5	~56	720	5,400	250	1.5	~70	570	5,130	250	1.5	~87	460	4,140
		300	0.8	~56	640	4,800	300	0.8	~70	510	4,590	300	0.8	~87	410	3,690
		350	0.6	~56	640	4,480	350	0.6	~70	510	4,280	350	0.6	~87	410	3,440
Stainless steel (SUS304) below 250HB	JC7550 SPMT-SM	~150	1.5	~56	600	4,200	~150	1.5	~70	480	4,030	~150	1.5	~87	380	3,190
		200	1.5	~56	600	3,900	200	1.5	~70	480	3,740	200	1.5	~87	380	2,960
		250	1.3	~52	520	3,120	250	1.3	~60	410	2,950	250	1.3	~75	330	2,380
		300	1.1	~52	480	2,400	300	1.1	~60	380	2,280	300	1.1	~75	310	1,860
		350	0.9	~52	400	2,000	350	0.9	~60	320	1,920	350	0.9	~75	250	1,500
Titanium alloy (Ti-6Al-4V)	DS150 SPMT-SM	~150	1.3	~56	240	720	~150	1.3	~70	190	680	~150	1.3	~87	150	540
		200	1.1	~56	240	720	200	1.1	~70	190	680	200	1.1	~87	150	540
		250	0.9	~52	240	600	250	0.9	~60	190	570	250	0.9	~75	150	450
		300	0.7	~52	240	480	300	0.7	~60	190	460	300	0.7	~75	150	360
		350	-	-	-	-	350	-	-	-	-	350	-	-	-	-

Note

1. Please adjust cutting conditions according to machine rigidity or work rigidity. (the above table is guide for cutting on a #50 BT machine.)
2. In case of chatter occurring, recommended to reduce a_p or rpm and keep feed per tooth.
3. a_p should be reduced when using on low rigidity machine.
4. Use air blow.

★: a_p ≤ 1.8 when using SPMT14 insert

SKS-GII**SKG/MSG Type**

■ Recommended cutting conditions

● SKG14 Type

Material	Grade	Tool dia.(mm)				
		160				
		7N				
		ℓ (mm)	a_p (mm)	a_e (mm)	n (min ⁻¹)	V_f (mm/min)
Carbon steel (S50C, S55C) below 250HB	JC8050 (JC8118) SPNW SPMT-PM	~150	2★	~112	300	3,780
		200	1.8	~112	300	3,780
		250	1.5	~112	280	2,940
		300	0.8	~112	260	2,730
		350	0.6	~112	220	2,160
Tool & die steel (SKD61, SKD11) below 255HB	JC8050 (JC8118) SPNW SPMT-PM	~150	2★	~112	300	3,780
		200	1.8	~112	300	3,780
		250	1.5	~112	280	2,940
		300	0.8	~112	260	2,730
		350	0.6	~112	220	2,160
Mold steel (HPM7, PX5, P20) 30-36 HRC	JC8050 (JC8118) SPNW SPMT-PM	~150	2★	~112	300	3,780
		200	1.8	~112	300	3,780
		250	1.5	~112	280	2,940
		300	0.8	~112	260	2,730
		350	0.6	~112	220	2,160
Mold steel (NAK80, HPM1, P21) 38-43HRC	JC8118 (JC8050) SPNW SPMT-PM	~150	1.6	~112	200	2,100
		200	1.4	~112	200	2,100
		250	1.2	~112	200	2,100
		300	0.7	~112	160	1,570
		350	-	-	-	-
Hardened die steel (SKD61, DAC, DHA) 42-52HRC	JC8118 SPNW	~150	1	~112	180	1,510
		200	1	~112	180	1,260
		250	0.8	~100	180	1,010
		300	0.5	~100	140	690
		350	-	-	-	-
Grey & Nodular cast iron (FC, FCD) below 300HB	JC8118 SPNW SPMT-PM	~150	2★	~112	360	4,540
		200	1.8	~112	360	4,540
		250	1.5	~112	360	3,780
		300	0.8	~112	320	3,360
		350	0.6	~112	320	3,140
Stainless steel (SUS304) below 250HB	JC7550 SPMT-SM	~150	1.5	~112	300	2,940
		200	1.5	~112	300	2,730
		250	1.3	~100	260	2,180
		300	1.1	~100	240	1,680
		350	0.9	~100	200	1,400
Titanium alloy (Ti-6Al-4V)	DS150 SPMT-SM	~150	1.3	~112	120	500
		200	1.1	~112	120	500
		250	0.9	~100	120	420
		300	0.7	~100	120	340
		350	-	-	-	-

Note

1. Please adjust cutting conditions according to machine rigidity or work rigidity. (the above table is guide for cutting on a #50 BT machine.)
2. In case of chatter occurring, recommended to reduce a_p or rpm and keep feed per tooth.
3. a_p should be reduced when using on low rigidity machine.
4. Use air blow.

★: $a_p \leq 1.8$ when using SPMT14 insert